



OPTIMA HOME OWNER'S MANUAL

CONTENTS

Introduction	3
Optima System Overview.....	4
Ventilation.....	6
Maintenance.....	6
Decoration.....	7
Tiling	7
Fixings	8



THE OPTIMA DRY LINING SYSTEM

What is Optima?

Isover Optima is a NSAI agreement certified internal wall insulation system designed to improve energy performance while helping to preserve the character of existing buildings. It offers a dry installation method, integrates airtightness and vapour control, and allows flexibility on-site. We provide standard guidance for typical applications, and our technical team is available to support more complex scenarios where building condition or moisture risks require specialist input.

Why choose Optima?

Optima is often suitable for consideration in conservation of old and historical buildings where there is solid wall construction, as it uses mineral based materials: mineral wool insulation and gypsum board, which do not need to be glued and therefore may assist to preserve the original elements while allowing for ongoing adaptation. The system further mitigates impact on the building by accommodating new services, and is designed for circularity through deconstruction with the mineral wool, clips and steel frame highly suitable for reuse¹.

Additional key benefits² are presented below:

- ✔ Contributes to system thermal and acoustic performance
- ✔ Thermal Bridge Mitigation
- ✔ Dry, clean, lightweight system with minimal waste, enabling rapid construction times
- ✔ Airtightness and moisture control membrane
- ✔ Economical



Where to use



Residential



Non Residential



New and Old

¹ Subject to certifier inspection and sign off.

² When installed in accordance with our recommendations.



OPTIMA DRY LINING SYSTEM OVERVIEW

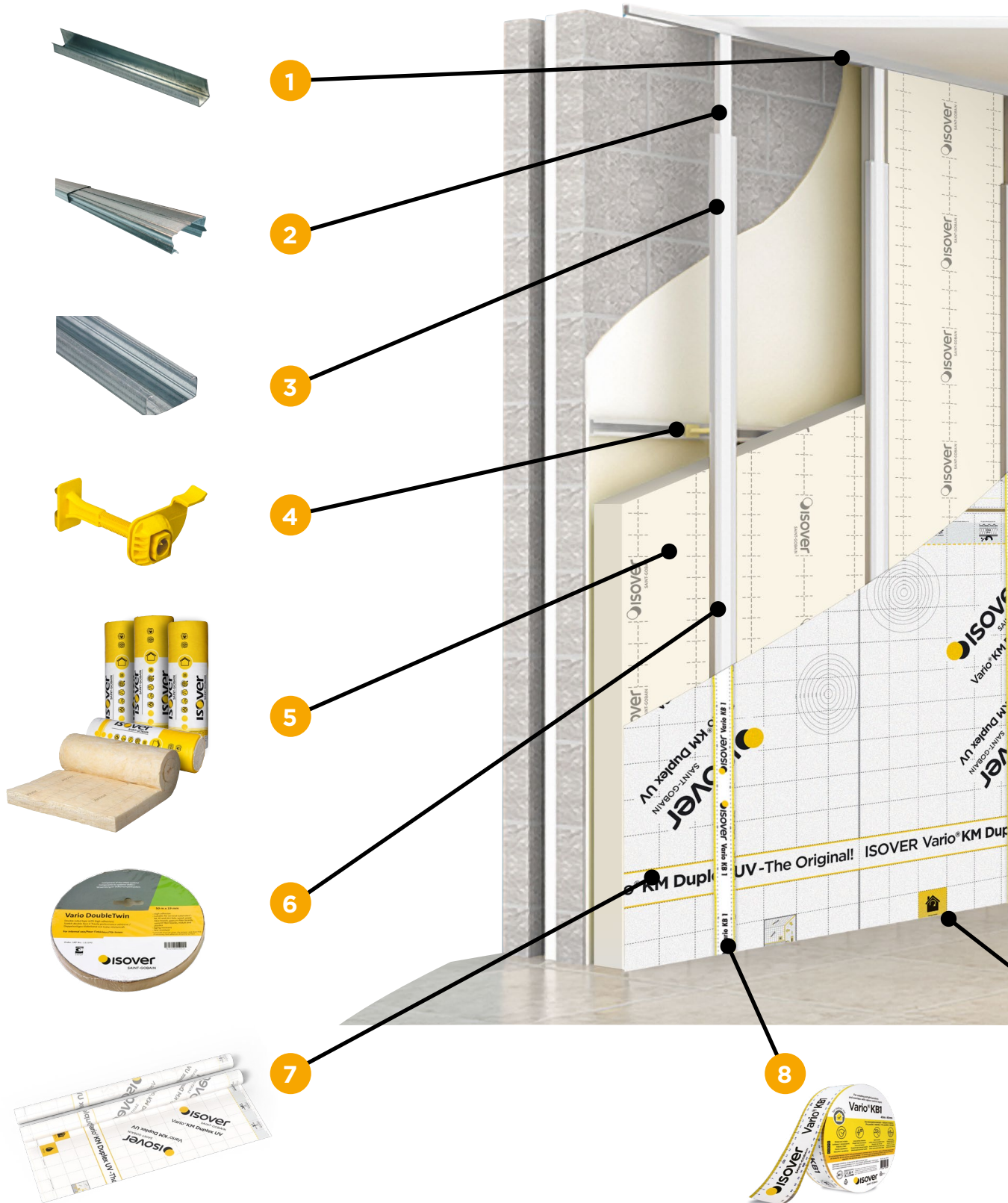

I. Metal frame

1. Optima Floor and Ceiling U-Channel
2. Optima 500mm Extension
3. Optima 2.4m C-Channel
4. Optima Support Clips for:
 - Reasonably plumb and level Optima Support
 - Very uneven Optima Direct Support (70-160)

II. Insulation

5. Isover Insulation Material, e.g.
 - Comfort 35 Lanaé (0.035W/mK)
 - Comfort Panel 32 (0.032 W/mK)

III. Airtightness & Moisture Control Layer

6. Vario® DoubleTwin
7. Vario® KM Duplex UV Airtightness and Vapour Permeable Layer
8. Vario® KB1 One-sided Adhesive Tape
9. Vario® DoubleFit+

IV. Facing

10. Gyproc Plasterboard
(Various specifications of boards available)
11. Decorative Finish
(Various specifications of Gyproc Finishing Plasters or Gyproc Taping and Jointing products available).

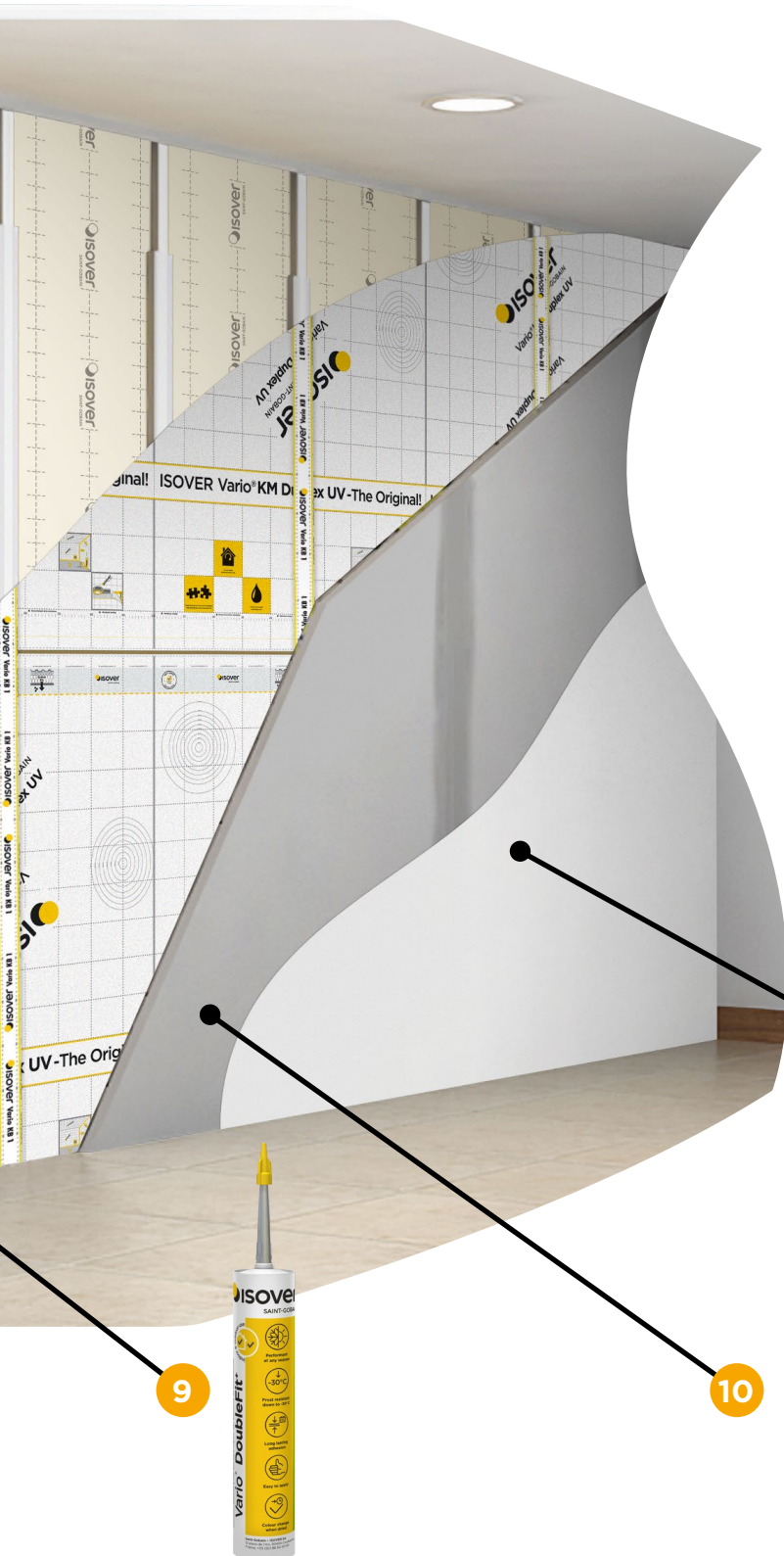



VENTILATION

Adequate ventilation is necessary to maintain a comfortable healthy environment, so it is essential that the ventilation system is not blocked or damaged in any way. If ventilation is being provided through vent pipes and/or trickle vents to windows these must be kept clear at all times to allow for adequate airflow.

Every day activities such as cooking or ironing can greatly increase the internal humidity level. While these activities are carried out the ventilation system, e.g. air extractors etc should be used actively to maintain normal levels of humidity. An appropriate ventilation system may also reduce the build up of Radon and pollutants in the air. In order to determine if additional measures should be considered, It is always recommended that homeowners carry out a Radon Survey. Information on how to go about this is available through the Environmental Protection Agency here: <https://www.epa.ie/environment-and-you/radon>.



Wall Vents

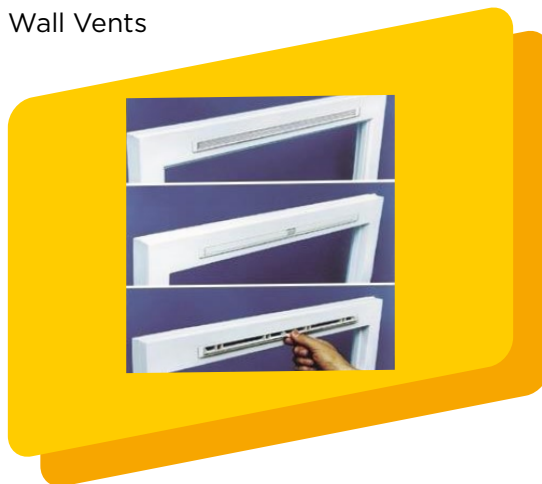

Trickle Vents

MAINTENANCE

Once installed in accordance with the manufacturer's instructions, The optima dry-lining system requires no particular maintenance.

It is important that leaks or exposure to other sources of moisture including high levels of humidity are removed/repared as soon as possible. Note that Gypsum-based products are not designed to be used in wet conditions; furthermore no guarantee can be provided for the short or long term performance of our products if they have been subjected to exposure to excessive water, such as in situations of flooding, burst pipes etc. In addition, water damage can cause permanent stains. When redecorating, fill any cracks and repair any scuffs or dents. Redecorate the wall surface.

Any small penetrations made in the plasterboard may be repaired with filler, however, openings larger than 150mm should be cut back and a backing frame installed to receive screw fixings on each side, e.g. Gyproc Gypframe GFS1 flat strap. Any penetrations made in the Isover Vario® Airtightness Membrane should be repaired and sealed with Isover Vario® MultiTape SL+.

DECORATION

- Apply finish coat plaster after the joint treatment has set.
- Build out to 2mm thickness in two applications, wet-on-wet and trowel to a smooth matt finish. Use water sparingly and only in the latter stages of trowelling.

Decoration:

- Ensure that the plasterwork is thoroughly dry before final decorating.
- Consult the paint manufacturer for advice on applying a suitable coat of permeable paint in the interim.
- Plaster surfaces can be decorated with most proprietary paint finishes and will accept the majority of wall covering adhesives.
- Always follow the manufacturers' recommendations in respect of applied decorative treatments.

It is important to note that only paint that allows the transmission of water vapour can be used with the Vario® system included. This should be checked with the paint manufacturer or supplier.



TILING

For areas to receive tiling, securely fix plasterboard to Optima channels installed at a maximum of 400mm centres. Tiles up to 32kg/m² can be applied to the plasterboard which should be dry, with no protruding fixings.



FIXINGS

Prior to the installation of Isover's Optima dry lining system, it is essential that you identify and advise the installer of the areas where you will require additional support for wall mounted fittings such as radiators, flat screen TVs etc... Note that the selection of Plasterboard type can impact on the capability of the wall to carry additional loads and reference should be made to the board specification prior to the subsequent installation of heavy loads.



FIXING TYPES

Masonry:

Fix into Masonry wall we recommend using Gypframe GL 11 GypLyner anchors at 600mm centre when fixing C-Channel and or Optima Direct Support to existing structure. Use appropriate fixings in pre drilled holes for floor and ceiling U-channel. Assessment to be carried out of existing substrate for suitability.

SAFETY OF FIXING ITEMS TO DRYLINED WALL

- Loads up to 10kg can be attached directly to the Plasterboard using picture hooks or similar, or plugs specially designed for this purpose.
- Loads of between 10–30kg can be attached directly to the Plasterboard using expansion plugs or butterfly fixtures at a minimum pitch of 0.40m between two attachment points.
- Loads in excess of 30kg must be attached by a system inserted directly in the structure.

In both of the latter cases, these loads should be limited to values equal to those introducing an overturning moment of 30kg per linear meter in the case of a static load (e.g., a washbasin) or 15kg per linear meter in the case of a dynamic load (e.g., a shelf). For any areas planned for notable loading, e.g. cabinets, in addition to the above requirements, studs should be reduced to 400mm centres and note that loads applied + 2.7m height above floor level should be fixed back to the primary masonry structure.

Fixing to Gyproc Rigidur board:

Loads of up to 55kg can be supported directly from the board without the need for additional grounds.

ATTACHING LOADS

Flat loads:

Lightweight flat objects (e.g. pictures and mirrors) can be simply hung with picture hooks or wood screws fixed directly into the board, without the need for support noggings (see main table below for loadbearing capacity).

When fixing flat loads, any two points of attachment must have a minimum distance of 150mm from each other. Failure to do so will result in the halving of the weight of the load able to be supported.





Cantilever loads:

Shelves and hanging cupboards can be attached with suitable cavity fixings. The choice of attachment method is dependent upon the weight, distance of the weight from the fixing, and dimensions of the object. When fixing cantilever loads, any two points of attachment must have a minimum distance of 150mm from each other. Failure to do so will result in the halving of the weight of the load able to be supported. Contact the fixing manufacturer for guidance when calculating cantilever loads.

Heavy loads:

Heavy loads (e.g. wash basins, sanitary units and radiators) should be fixed to the primary masonry structure. Examples of the pull out capacity of various fixings in Rigidur are given in the table below:

Many different loads may be mounted to Gyproc Rigidur using suitable methods of attachment. Lightweight objects can be simply hung with picture hooks fixed directly into the board.

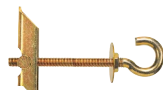
Board Lining	Fixing Type		Safe Working Load Per Fixing*	
			Pull Down	Pull Out
Single Layer Rigidur H	Single picture hook and masonry nail		12.5mm = 17kg 15mm = 18kg	
Single Layer Rigidur H	Number 10 woodscrew			12.5mm = 30kg 15mm = 30kg
Single Layer Rigidur H	'Fischer PD' nylon plug and screw			12.5mm = 20kg 15mm = 20kg
Single Layer Rigidur H	'Fischer UX (8 x 50)' nylon plug and screw			12.5mm = 21kg 15mm = 27kg
Single Layer Rigidur H	'Fischer HM8 x 55' steel cavity fixing			15mm = 49kg
Single Layer Rigidur H	'Fischer KD6' steel cavity fixing			12.5mm = 17kg 15mm = 74kg

Note:

*Safe working loads, were calculated using a safety factor of $\times 4$ for metal fixings and $\times 7$ for plastic fixings as per Construction Fixings Association guidance. Please refer to the fixing manufactures' recommendations when mounting and fixing.



Depending on the type and capacity of the method of attachment, various vertical loads can be supported by Gyproc Rigidur. Shelves and hanging cupboards can be attached with suitable cavity fixings. The choice of attachment method is dependent upon the weight and dimensions of the object. Loads with a weight of less than 30kg per point of attachment can easily be attached to the wall with suitable screws, and 55kg using a suitable wall plug, without the need for support noggings.

Any two points of attachment must have a minimum distance of 150mm from each other, otherwise the weight of the load able to be supported must be halved. Heavy loads (e.g. sinks, sanitary units and radiators) should be affixed to the sub layer construction.

Load-bearing capacity kg*

Thickness
(mm)

Picture Hooks Fixed by Nails

Screw with
Continuous
Thread 5mm dia. Toggle Bolt

Thickness (mm)	Picture Hooks Fixed by Nails			Screw with Continuous Thread 5mm dia. Toggle Bolt	
10	15	25	35	20	40
12.5	17	28	38	30	50
15	18	30	40	30	55

Note:

*Loads are also subject to fixing quality.

When using standard Gyproc Wallboards please note the following details:

There is a wide variety of fixing devices suitable for securing fixtures and fittings to the Isover Optima systems. Generally, the choice of individual fixing devices will depend on the loading requirements. This section gives recommendations on the selection of generic devices and proprietary fixings. The Table below gives example fixing devices and typical applications using Gyproc Wallboard to meet the specific load criteria. The guidance given is primarily concerned with fixtures at the time of installation. Subsequent installation is less easy, especially for heavier fixtures that will often require considerable care, if the lining is not to be locally deflected.



Superior load-bearing capacity

Distance to The Centre
of The Object (mm): t





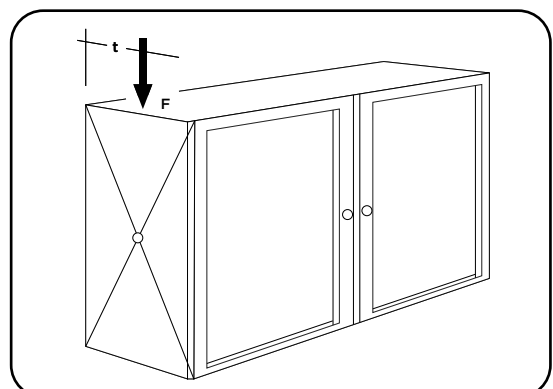







Load Per Fixing
(kg): F

100	80
200	73
300	70
400	63



Plaster Board Fixing Table

The example fixing devices, typical safe working and failure loads in this table relate to the installation of single fixtures. It is important to ensure that the specified loads may be carried by the Optima system, particularly if installing multiple fixtures.

Ref	Detail	Description	Typical SWL* (Typical Failure Load)
A		No. 10 woodscrew into Gyproc Plasterboard	3kg (12kg)
B		Steel picture hook and masonry nail into Gyproc Plasterboard	4kg (16kg)
C		Metal self-drive into single layer Gyproc Plasterboard	6kg (24kg)
		Metal self-drive into double layer Gyproc Plasterboard	8kg (32kg)
D		Steel expanding cavity fixing, e.g. M5 × 40, into Gyproc Plasterboard (board thicknesses upto 12.5mm)	12kg (48kg)
		Steel expanding cavity fixing, e.g. M5 × 65, into Plasterboard (board thicknesses from 15mm to 28mm)	18kg (72kg)
E		Gyproc Drywall Screw fixed through Gyproc Plasterboard into 0.5mm Gypframe metal stud / Gypframe 99 FC 50 Fixing Channel	19kg (76kg)
F		Heavy duty plastic plug fixed through Gyproc Plasterboard into masonry with 55mm minimum penetration	20kg (140kg)
G		Gyproc Jack-Point Screws fixed through Gyproc Plasterboard into minimum 0.9mm Gypframe metal stud / Gypframe 150 FC 90 Fixing Channel	30kg (120kg)
H		No. 12 self-tapping screws fixed through Gyproc Plasterboard into minimum 0.9mm Gypframe metal stud/ Gypframe 150 FC 90 Fixing Channel	50kg (200kg)
I		Steel expanding metal cavity fixing, e.g. M4 × 40, through Gyproc Plasterboard into 0.9mm Gypframe metal stud / Gypframe 150 FC 90 Fixing Channel (board thicknesses upto 12.5mm)	40kg (160kg)
		Steel expanding metal cavity fixing, e.g. M4 × 65, through Gyproc Plasterboard into 0.9mm Gypframe metal stud / Gypframe 150 FC 90 Fixing Channel (board thicknesses from 15mm to 28mm)	50kg (200kg)
		Steel expanding metal cavity fixing, e.g. M5 × 65, fixing through Gyproc Plasterboard into plywood supported by Gypframe Service Support Plate	50kg (200kg)
J		8mm steel frame fixing fixed through Gyproc Plasterboard into masonry with minimum 55mm penetration	60kg (240kg)
K		No. 12 self-tapping screw fixed through Gyproc Plasterboard into timber sub-frame	120kg (480kg)
L		M8 Steel bolt/ anchor fixed through Gyproc Plasterboard into masonry with minimum 55mm penetration	130kg (520kg)

Note: *Safe Working Load (SWL) - a safety factor of 4 (steel fixings) and 7 (plastic fixings) has been used. For technical assistance on above fixings please contact the fixings manufacturer. The suitability of the fixing must be confirmed by the building designer / fixing manufacturer. Reference can also be made to the Construction Fixing Association (CFA) guidance note 'Fixing For Plasterboard', which is currently under review by the CFA and can be accessed at www.fixingscfa.co.uk

Need regulatory advice?



Contact our technical team

ROI
1800 744480

NI
0845 399 0159

EMAIL
tech.ie@saint-gobain.com



SAINT-GOBAIN

Isover Ireland

Unit 4, Kilcarbery Business Park,
Nangor Road, Dublin 22
D22 R2Y7
Telephone: 01 629 8400
Email: info@isover.ie
www.isover.ie



@SaintGobainGroup



Saint-Gobain



@saintgobain

Gyproc, Gypframe and Glasroc are all registered trade names of Saint-Gobain Construction Products (Irl) Limited. Isover is a registered trade name of Saint-Gobain. Saint-Gobain Construction Products (Irl) Limited reserves the right to revise product specifications without notice. The information in this document was correct to the best of our knowledge at the time of publication. It is the user's responsibility to ensure that it remains current prior to use. The information in this document is for guidance only and should not be read in isolation. Users should read and familiarise themselves with all the information contained in this document and ensure that they are fully conversant with the products and systems being used, before subsequent specification or installation. For a comprehensive and up-to-date library of information visit the Isover website at: www.isover.ie